

///ATOM[®]

PATENTED WORLD'S BEST LAWN EDGERS

Model 301

Electric

OPERATOR/OWNER MANUAL

- Safety Precautions
- Assembling
- Operating & Edging Instructions
- Maintenance & Workshop Manual



ACN 000 583 924

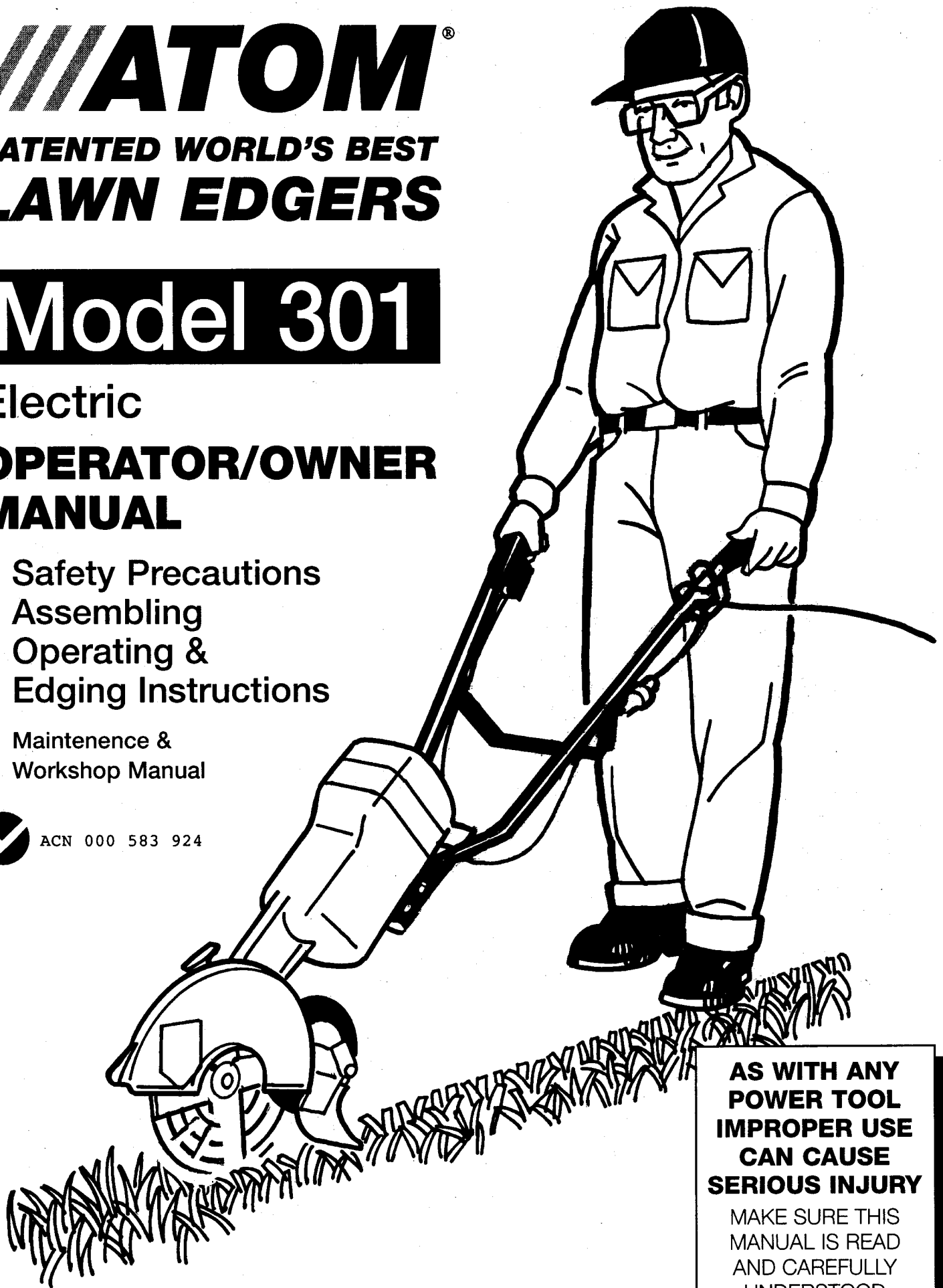

**AS WITH ANY
POWER TOOL
IMPROPER USE
CAN CAUSE
SERIOUS INJURY**

MAKE SURE THIS
MANUAL IS READ
AND CAREFULLY
UNDERSTOOD
BEFORE STARTING
OR OPERATING
THIS EQUIPMENT

IMPORTANT MANUAL - DO NOT THROW AWAY

Manual always to be available for reference or instructing new operators.
Please fill in details of purchase on back cover page.

INTRODUCTION

This Atom Electric Powered Lawn Edger is designed to the highest standards to ensure you many hours of uninterrupted service.

Pay special attention to the safety precautions outlined on pages 2 to 5. Only persons who understand this Manual are to operate the Lawn Edger.

To receive maximum performance and satisfaction from your Lawn Edger, it is important that you read and understand the maintenance and safety precautions before using the edger. Contact your Atom dealer or the Atom distributor in your area if you do not understand or cannot carry out any of the operating instructions in this Manual.

Atom's philosophy is to continually improve all of its products. As a result, engineering changes and improvements are made from time to time. If the operating characteristics or the appearance of your Atom Edger differs from those described in this manual, please contact your Atom dealer for information and assistance. Call (02) 9810 0194 (within Australia) for your nearest servicing dealer.

NOTE: OUTSIDE AUSTRALIA REFER TO BACK COVER PAGE

CONTENTS

Parts and Controls	2-3
Safety Precautions	3-5
Assembling the Lawn Edger	6
Starting and Stopping Instructions	6
Edging Instructions	7-8
Maintenance Instructions	
Blade Replacement	9
Lubrication of Gears	9
Removing Blade Cover	9
Trouble Shooting tips	10
Parts List and exploded View	18-19
Included at the rear of this manual is a complete workshop manual which is information for persons with suitable servicing experience should this unit ever require workshop repair	10
Warranty	20

TO SERVICE OR REPAIR UNIT

A. To Replace Driveshaft.	
How to remove wheel arm	10
B. Motor does not switch on. How to adjust switch cable	11
C. How to repair switch trigger assembly	11
D. How to remove and replace switch cable, motor clutch and fan	12
E. How to remove and replace main crown gear and pinion drive shaft	14
F. Replacing clutch drum – Early model	15
Replacing clutch drum – Late model	15
G. Final assembly of main housing, gear drive and testing	16-17

SAFETY WARNINGS

THE PURPOSE OF SAFETY WARNING AND NOTES IN THIS MANUAL IS TO ATTRACT YOUR ATTENTION TO POSSIBLE

DANGERS AND THE EXPLANATIONS WITH THEM DESERVE YOUR CAREFUL ATTENTION AND UNDERSTANDING. THE SAFETY WARNINGS IN THIS MANUAL AND ON THE EDGER DO NOT, BY THEMSELVES, ELIMINATE ANY DANGER. THE INSTRUCTIONS OR WARNINGS THEY GIVE ARE NOT SUBSTITUTES FOR PROPER ACCIDENT PREVENTION MEASURES.

WARNING

Failure to obey a safety warning can result in injury to yourself and others.

NOTE

Advises you of information or instructions vital to the operation or maintenance of the equipment.

PARTS & CONTROLS

- 1,2 The **handles** of the Lawn Edger are held by both hands.
- 3 The **throttle trigger** which starts electric motor for automatic motor clutch to engage and thus rotate blade.
- 4 **Exterior cord and anchor.**
- 5 **Warning Label** on blade guard.
- 6 **Handle nut** for holding handles onto housing.
- 7 **Height adjustment** for adjusting depth of cutting blade.
- 8 **Blade cover** reduces the risk of flying debris and direct contact with the feet or hands.
- 9 **Sight guide** for edging.
- 10 **Cutter blades** rotate when motor is switched on.
- 11 **Grass shield** debris deflector reduces flyback of stones and foreign material.
- 12 **Wheel** for moving and guiding edger.
- 13 **Cross Brace**, attaches downward on handle.
- 14 Left and right **Handle Tubes**.
- 15 **Motor which drives the blades.**
- 16 **Cable loop holder.**

PARTS & CONTROLS (CONTINUED)

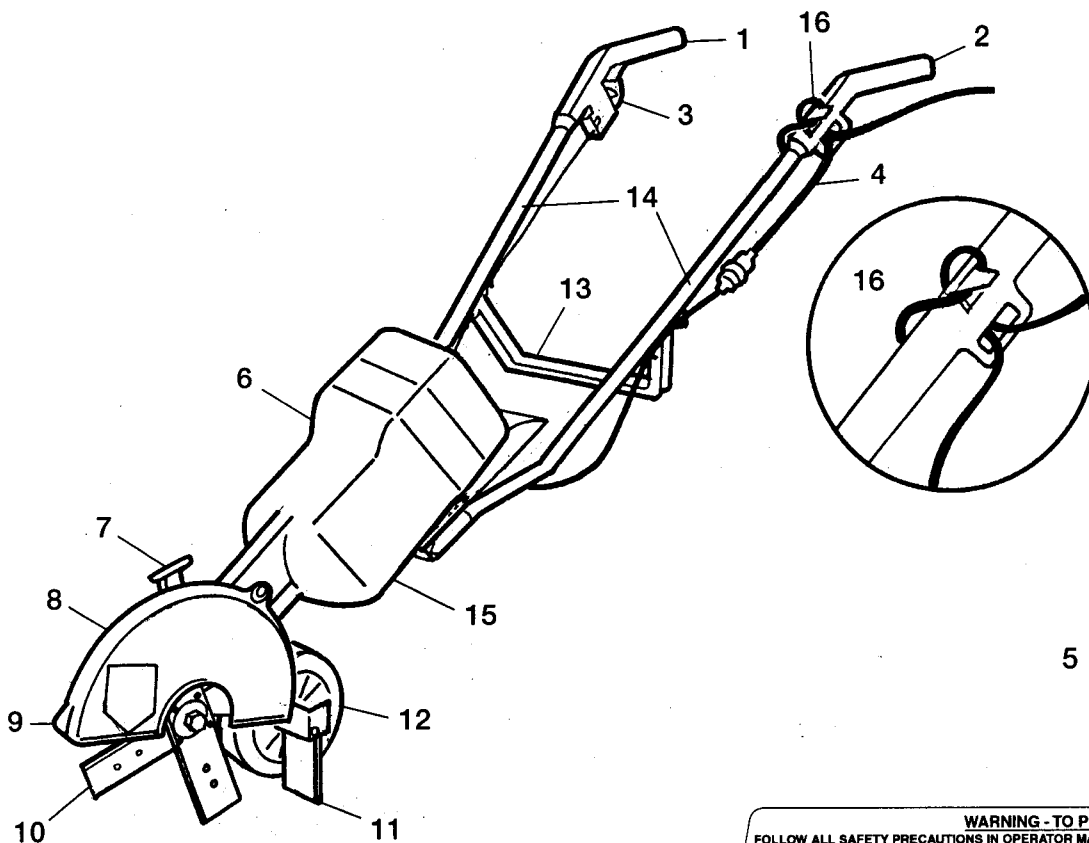

Model No	301
Insulation throughout	Double insulated
Motor	Universal heavy duty ball bearing type Motor Manufacturers rating: 1350 watts
Voltage	230/240 volts AC
Air Cooling	Fan forced
Cutting Depth	Up to 75mm
Automatic centrifugal clutch	Protects motor when blade jams or hits hard objects while edging. Refer pages 5 & 7.

WARNING
KEEP INSIDE OF BLADE GUARD CLEAN, ESPECIALLY IN WET CONDITIONS. A CLOGGED GUARD CAN SLOW DOWN OR STOP BLADE ROTATION AND MAY CAUSE DAMAGE TO AUTOMATIC SAFETY CLUTCH. ALWAYS OPERATE BLADE AT HIGH SPEED WHEN EDGING.

DANGER!
KEEP HANDS & FEET AWAY

ROTATING BLADE
DIRECTION OF ROTATION

WARNING - TO PREVENT SERIOUS INJURY (P/N 961-01101)
FOLLOW ALL SAFETY PRECAUTIONS IN OPERATOR MANUAL - IMPROPER USE CAN CAUSE SERIOUS OR FATAL INJURY ● OBJECTS MAY BE THROWN OR RICOCHET IN ALL DIRECTIONS - ALWAYS WEAR EYE PROTECTION ● KEEP BYSTANDERS AT LEAST 50FT (16M) AWAY ● ALWAYS WEAR EAR PROTECTION ● WEAR SNUG FITTING CLOTHING ● MINORS SHOULD NEVER BE PERMITTED TO USE THIS EDGER ● WEAR STURDY SHOES WITH NON-SLIP SOLES ● DO NOT LEND, RENT OR SELL THIS EDGER WITHOUT THE OPERATOR MANUAL.

SAFETY PRECAUTIONS

! WARNING As with any power tool, the use of any lawn edger may be dangerous. It is important that you read, fully understand, and observe the following safety precautions and warnings. Re-read this operator's manual and the safety instructions periodically.

! WARNING Do not lend, rent or sell this machine without the operator's manual. Be sure that anyone using this unit understands the information contained in this manual before use.

! WARNING As with any power tool, some special safety precautions must be observed to reduce the risk of personal injury. Careless or improper use may cause serious or even fatal injury.

THE OPERATOR

PHYSICAL CONDITION

Operator must be in good physical condition and mental health, and not under the influence of any substance (drugs, alcohol, etc.) which might impair vision, dexterity or judgement (Fig. 3).



FIG 3

! WARNING This Lawn Edger must not be operated by minors. Bystanders, especially children and animals, should not be allowed in the area where a machine is in use at least 15 metres (50 feet) away (Fig. 4). Never let the unit run unattended.

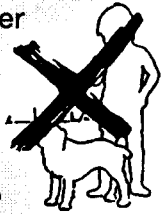

FIG 4

! WARNING Electrical shock. Replace immediately any faulty lead or plug.

Safe use of an Atom Lawn Edger involves:

1. The Operator
2. The Atom Edger
3. The use of the Atom Edger

SAFETY PRECAUTIONS (CONTINUED)

Do not operate the Edger when fatigued. Be alert - if you get tired while operating the machine, take a break. Tiredness may result in loss of control. Working with any power tool can be strenuous. If you have any condition that might be aggravated by strenuous work, check with your doctor before operating the machine.

! WARNING Prolonged use of any hand-held powered machine exposing the operator to vibrations may produce whitefinger disease (Raynaud's phenomenon) or carpal tunnel syndrome. These conditions reduce the hand's ability to feel and regulate temperature, produce numbness and burning sensations, and may cause nerve and circulation damage and tissue necrosis.

PROPER CLOTHING

Clothing must be sturdy and snug-fitting, but allow complete freedom of movement (see Fig. 5). Avoid loose-fitting jackets, flared or cuffed pants, or anything that could trip the operator. Wear overalls or long pants to protect your legs. DO NOT wear shorts. Use of gloves when working with the Lawn Edger is recommended.

Good footing is most important. Wear sturdy shoes with nonslip soles. DO NOT wear sandals or operate with bare feet. In hot or sunny conditions, always wear a hat and long sleeve shirt for protection against skin cancers. Use of a good brand of sunscreen cream is also recommended on exposed skin surfaces.

FIG 5

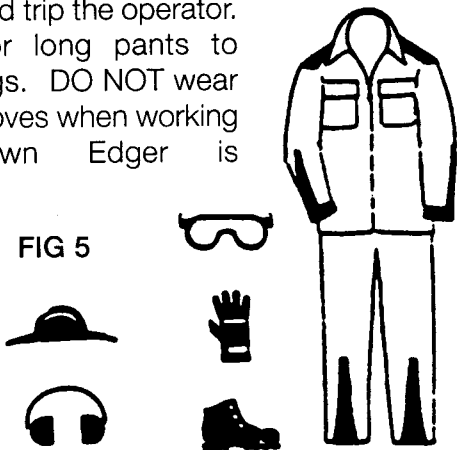

! WARNING Proper eye protection is a must. The blade cover may not protect the operator from all fast moving foreign objects, even though the discharge is directed away from the operator, as ricochets and bouncebacks may occur during lawn edging operations. Never operate an Atom Edger unless wearing goggles or properly fitting safety glasses with adequate top and side protection which comply with ANSI Z 87.1.

Replace immediately broken or cracked blade covers and grass shield debris deflector.

Engine noise may damage your hearing. Wear sound barriers (ear plugs or ear muffers) to protect your hearing. Continual and regular users should have their hearing checked regularly.

SAFE STARTING

You should always inspect your unit before starting it. Make sure the controls and safety devices are working properly.

Place the machine on firm ground or other solid surface in an open area. Maintain good balance and secure footing.

Failure to follow this procedure may result in injury.

! WARNING The Atom Edger is a one-person machine. To reduce the risk of eye or other injury from thrown objects, ensure that bystanders are at least 15 metres (50 feet) away during use. Replace immediately any worn or broken debris deflector shield or blade cover. If approached, release throttle trigger to immediately stop the motor.

SAFE WORKING INSTRUCTIONS AND IMPORTANT ADJUSTMENTS

Never operate your machine if it is damaged, improperly adjusted or not completely and securely assembled.

SAFE MAINTENANCE, REPAIR AND STORING

Use only original Atom replacement parts for maintenance and repair. Use of parts manufactured by others will void warranty and/or may cause serious or fatal injury.

! WARNING Always stop the motor, make sure that the blade is stopped, and disconnect the plug before adjusting blade height, doing any maintenance or repair work, or cleaning the unit or blade.

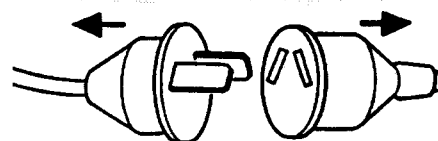

FIG 6

Follow the maintenance instructions in the appropriate section of this manual. Any repairs should be carried out by an authorized service dealer or person with suitable servicing experience.

SAFETY PRECAUTIONS (CONTINUED)

SAFE WORKING CONDITIONS

When working with the Atom Edger, always wrap your fingers tightly around each handle. Keep your hands *in this position to have your machine under control at all times.* NEVER attempt to operate the Atom Edger with one hand, *as a loss of control may result in serious or fatal injury* (Fig. 7).

Make sure the handle grips are in good condition *and free of moisture, pitch, oil or grease.* Use both hands, *one on each handle, to operate and control the lawn edger.* Do not overreach. Keep proper footing and balance at all times



FIG 7

! WARNING Cutting blade can cut extension cord. Keep the extension cord away from the cutting blade (Fig 00). A cut extension cord is dangerous and can be fatal to you or others. Replace immediately any worn or broken debris, deflector shield or blade cover.

ELECTRICAL SAFETY

1. This double insulated electric edger model no. 301 is only to be used on 240 volt power supply.
2. Where possible use an approved Earth Leakage Circuit Breaker (Residual Current Device) safety switch at the powerpoint or switchboard.
3. Avoid dangerous situations. Do not use in the presence of flammable liquids or gases to avoid creating a fire or explosion and/or cause damage to unit.

! WARNING Do not use in rain, in damp or wet locations, or around swimming pools, hot tubs etc. Do not expose to water, rain, or snow to avoid the possibility of electrical shock.

4. Do not attempt to repair unit. If there is any damage, do not use until damage is repaired by an authorised service centre.
5. Damaged supply cord (on lawn edger). This must be replaced by an authorised service agent or similarly qualified person in order to avoid a hazard.
6. Never carry the unit by the extension cord or yank the extension cord to disconnect the unit.

! NOTE

Use extension cords specifically marked as suitable for outdoor appliances. These have minimum 1mm diameter copper wire. In Australia, these are now yellow in colour. Do not use white coloured or light gauge undersized extension cords as these will cause a drop in line voltage resulting in loss of power and overheating. If in doubt, use the next heavier gauge. Inspect the extension cord before each use and do not use if damaged in any way.

7. To reduce the possibility of the extension cord disconnecting from the unit during operation, loop the extension cord to the extension cord anchor as shown (Fig. 8).

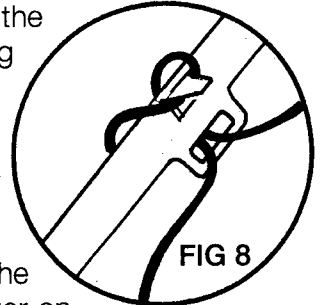

FIG 8

8. Do not use the edger if the switch does not turn the edger on and off properly. Repairs to the switch must be made by qualified electrical service personnel.

9. Keep the extension cord clear of operator and obstacles at all times. Do not expose the cords to heat, oil, water, or sharp edges. Do not edge next to cord, or walk on or drive over cord.

10. When cleaning, disconnect electrical cable (Fig. 9) and do not use water. Scrape dirt away with a piece of

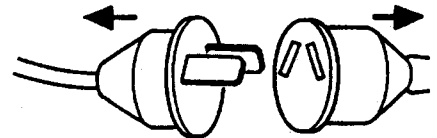

FIG 9

branch, wood, screwdriver etc. If accidentally wetted by water, allow to dry in the sun, inspect and ensure it is dry before use.

11. Do not store unit outside but only indoors in a secure dry place leaning against a wall with handles uppermost.

ASSEMBLING THE ///ATOM LAWN EDGER

- A. Fit left handle tube #1 to edger body #2 as shown. Note: Left handle has warning label (Fig.10).
- B. Insert 150mm (6") bolt #3 through handle bolt hex head retainer #9 then through left handle tube #1, edger body #2 and right handle tube #11. Note: Plastic retainer #9 to be pointing forward.
- C. Screw large wing nut #10 on protruding bolt #3 and tighten.
- D. Fit cross-brace #4 to handles #1 and #11 with brace touching ground. Use 2 screws #5 and 2 lock nuts #6 provided in packet. Use straight bladed screwdriver (or Torx 25 screwdriver)
- E. Insert trigger handle #7 into right handle tube #11 using one screw #5 and one nut #6 to hold in place. Note: Throttle cable/switch wire from engine must be fitted under handle and clipped into holding lugs of cross-brace #4. Do not loop throttle cable/switch wire over handle.
- F. Insert left handle #8 into left handle tube #1 using one screw #5 and one nut #6 to hold in place.

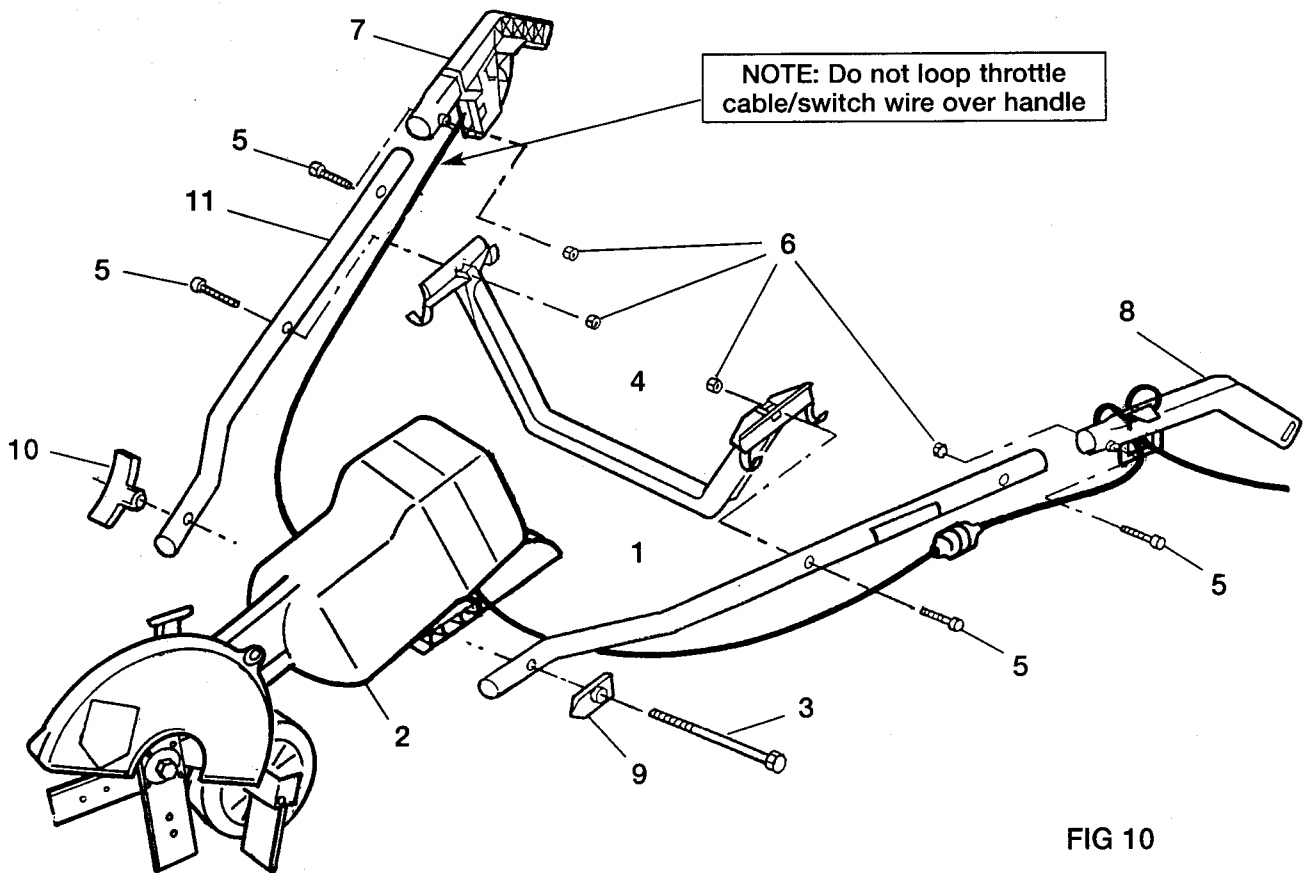
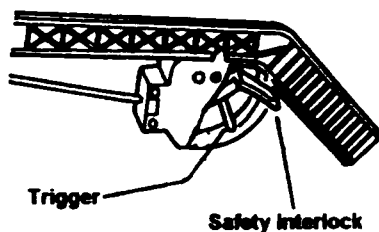

FIG 10

STOPPING AND STARTING INSTRUCTIONS

To start motor hold firmly left and right handle grips and ensure blade is out of ground. With right thumb press down safety interlock and pull back trigger. Motor and blade will instantly start to turn.

To stop motor release throttle trigger.



WARNING Never use unit on wet grass, in rainy conditions or where there is dew or moisture around. Never hose unit with water to clean.

EDGING INSTRUCTIONS

1. The edger is very easy and simple to use and most operators can immediately adapt to its unique flexible use.

For some people it may take a few edgings to become accustomed to its operation.

2. Thoroughly inspect the area where the edger is to be used and remove all stones, sticks, wires and all other foreign objects.

3. Adjust blade depth: Try second hole closest to operator (Fig. 12)

! NOTE Failure to adjust blade to correct edging height will cause overheating of motor and clutch due to blade rotation stopping.

! NOTE When cutting efficiently, motor will turn blades at high speed.

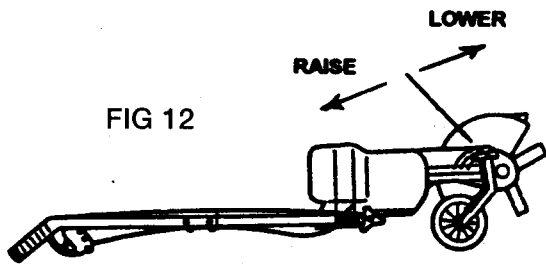

FIG 12

4. With both arms fully extended downwards (see illustration on front cover) hold both handle grips firmly.

The blade should just clear the ground. The blade is now set high so it can only cut if you lift your arms slightly (100mm) (Fig 13).

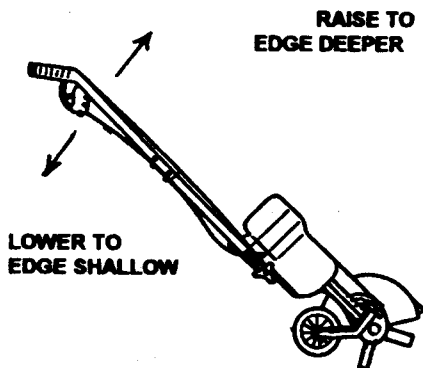

FIG 13

5. Pull throttle trigger allowing motor to start. You can practice walking forward on an area of your lawn or garden slightly lifting your arms, holding handles firmly for the blade to cut into the ground. This will give you a "feel" of the operating technique. If no. 2 position is too high then set at no.3 position.

6. Do not lift handles by excessive bending of elbows (Fig 14). Always keep arms straight as shown on Front Cover.



FIG 14

! WARNING Only operate unit when moving forward. DO NOT operate walking backwards, as you may trip, fall and injure yourself.

7. As cutting action begins, move the lawn edger forward so that the blade can cut the edge as you move forward (Fig. 15).

8. Continue at a moderate pace until you are familiar with the controls and the handling of the Atom Edger.

9. If blade jams or stops in the ground (Fig. 16), lower handles or pull back unit and recommence. Motor should be at full speed under load.

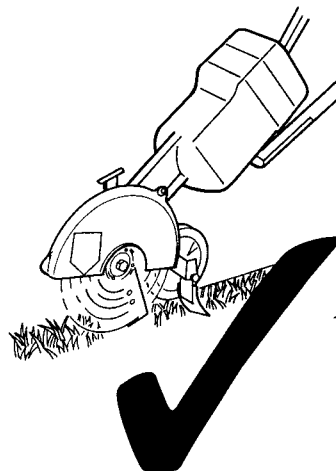

FIG 15

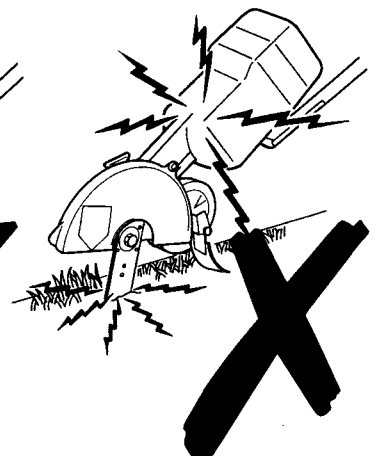

FIG 16

! NOTE Allowing motor to run excessively (1-2 minutes) with blades not rotating will cause clutch to burn out.

EDGING INSTRUCTIONS (CONTINUED)

10. **Edging along Concrete edge:** For position of blade, align edge guide (at front of blade cover) with edge of concrete. If blade hits concrete, lower handles and re-position blade at side of concrete. Even with the grass growing over the concrete and you cannot see the edge, **you can feel the edge of the concrete with the rotating blade by slightly sideways tilting the handles of the edger away from the concrete so that the blade tilts towards the concrete and touches or "kisses" the concrete edge and acts as a guide (Fig 18).** Edger blades are made from high tensile hardened spring steel and will last a long time. Once the edge is established the second and subsequent times around are very fast.

11. **Edging against walls or fences:** To sideways tilt, lower one hand and lift other hand and slowly walk along wall or fence cutting the ground just below ground level (Fig. 19).

12. **Clutch:** The Atom Edger is equipped with a centrifugal clutch. **DO NOT** run edger at low speeds (or, if blade is jammed, and motor is still switched on. Stop motor and pull back unit and recommence edging. Reduce cutting depth as clutch shoes will prematurely wear and cause damage if cutting blades do not rotate.

! NOTE

Keep inside of blade guard clean, especially in wet conditions. A clogged guard can slow down or stop blade rotation and may cause damage to automatic safety clutch. Always operate blade at high speed when edging.

13. The Lawn edger can be transported by pushing it on it's wheel, or carrying it **with motor switched off** as in Fig. 17

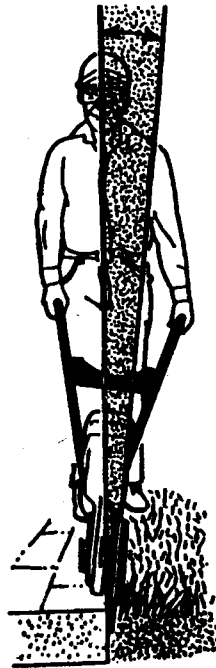
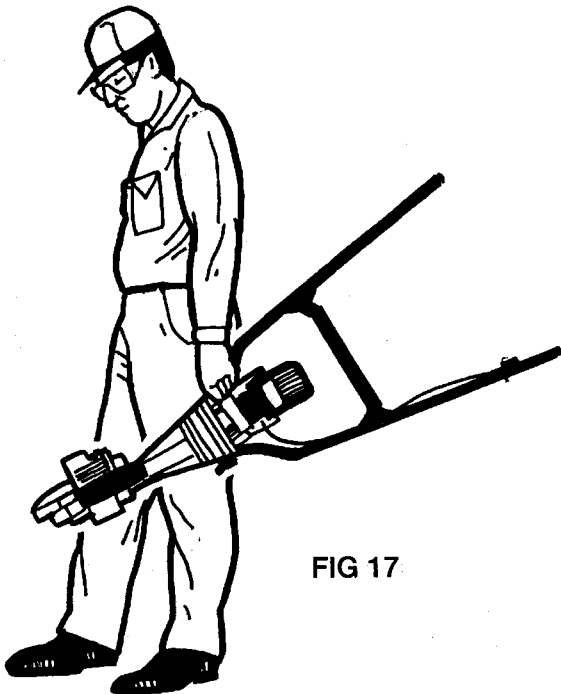

! WARNING TO AVOID PERSONAL INJURY, NEVER CARRY THE EDGER WHILE THE MOTOR IS RUNNING. Never hold the handle cross brace if the motor is running (Fig.20). Stop the motor prior to lifting or carrying.

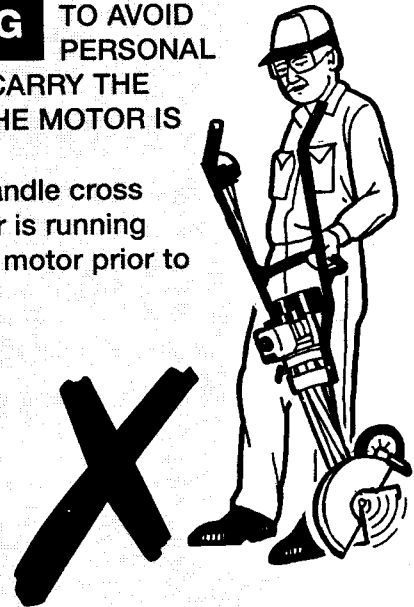
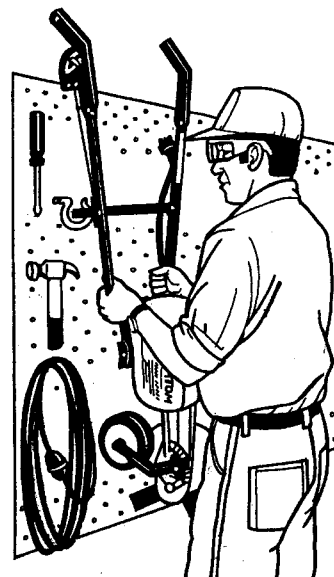

FIG 20



MAINTENANCE INSTRUCTIONS

BLADE REPLACEMENT

1. Blade holding nut can be spun off with an impact drive. Alternatively, stop motor. Clean area around dust cover #43770 and pry out with screwdriver (Fig. 21) exposing 14mm hex head for unscrewing blade nut.

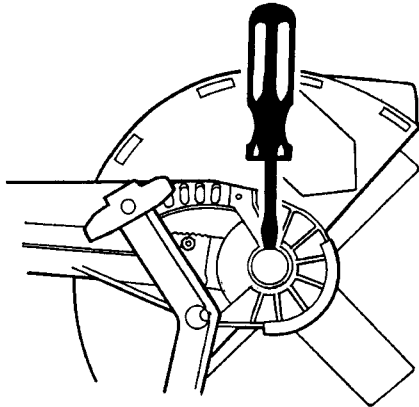

FIG 21

2. Through dust cover hole, place 14 mm socket and place 17 mm wrench on blade nut (Fig. 22).

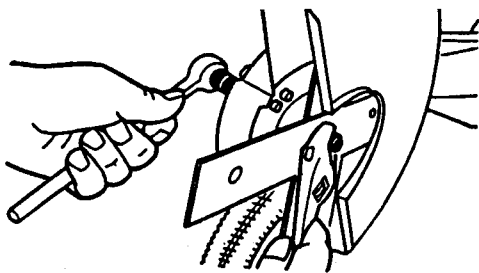

FIG 22

3. Unscrew nut counter (anti) clockwise (normal right hand thread) (Fig. 22).

4. Remove one small washer, one large washer and two blades (Fig 24), later models do not have small or large washers (Fig. 23 & 24). Before installing, clean all grit and grease. Assemble these parts clean and dry. Fit large washer (only on early models), new blades with spigots of one blade interlocking with holes on opposite blade, large washer, one small washer, and nut. Tighten nut to 15-20 ft. lbs. (20-27Nm) or hand tight with 8" (200mm) or longer spanner.

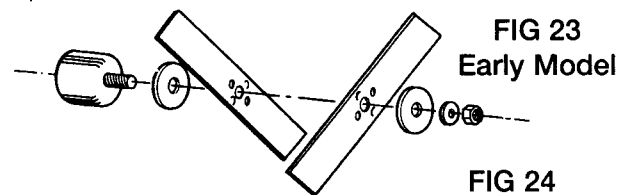

FIG 23
Early Model

FIT BLADES AT RIGHT ANGLES. 2 SPIGOTS ON EACH BLADE FIT INTO HOLES OF OTHER BLADE

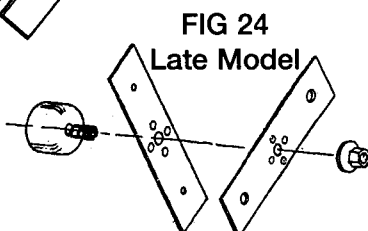

FIG 24
Late Model

5. Clean plastic dust cap and housing; press back by gently tapping into place. Clean inside blade cover of any built up dirt, or with impact driver, spin nut on.

! WARNING USE ONLY ATOM BLADES. Other blades have larger size holes (1/2") which will cause out-of-balance vibrations which will damage unit and cause injury. Other blades can also break and cause major injury.

! NOTE Do not run motor without blade tightened to blade shaft as gear damage will occur. Always use two blades as shown above. Never use a single blade. Do not use other thicker blades as you will damage the unit.

TO REMOVE BLADE COVER LID

For cleaning (or major repair).

1. Lift and tap with hammer in a clockwise direction (Fig. 25 - A).

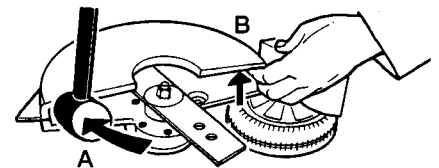

FIG 25

2. To re-install, press down lid in centre and tap with hammer counter (anti) clockwise (B).

LOOSE BLADE

Follow steps 1 and 2 of Blade Replacement and tighten nut clockwise.

LUBRICATION OF GEARS

Only required if gearbox shows leakage or is noisy.

There is usually sufficient grease to last at least 5 years before topping it up. The grease in the gear case should be added to according to use. Use a light, free-flowing lithium-based grease such as Castrol EPL1 or its equivalent. This is available in a handy to use squeeze pack with nozzle (#43227). Remove two screws marked FILL and BLEED. Inject grease into FILL screw hole and allow grease to eject from BLEED hole indicating gear box is 3/4 full (Fig. 26). Refit and tighten BLEED screw and squeeze in 3 to 4 more lots of grease. Refit FILL screw and tighten.

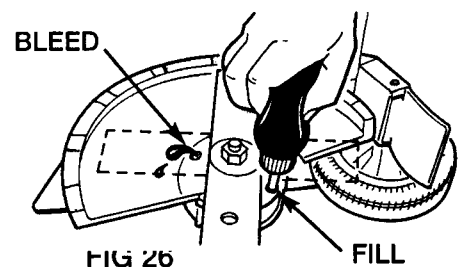

NOTE: Do not use light or heavy gear oil as it might leak out. If gear case shows leakage use heavier grease (e.g. Castrol EPL2). If case joint is damaged, clean and dry and use a gasket sealant. Replace o-ring if damaged. Tighten all screws. Refill casing.

TROUBLE SHOOTING TIPS

Problem	Cause	Action	Ref.
1. Cutting blade does not turn when operating	Blade cover filled with dirt/grass Clutch slipping Loose blade nut Blade stops under load	Clean Cut less depth or clean Tighten blade Cut less depth	Page 7 & 8 Page 7 & 8 Page 9 Page 7 & 8
2. Gear case Leaking	Loose screws Broken "O" ring Leaking around screw thread	Tighten Replace Re-fix screw	Page 9 & 16
3. Noisy gears	No oil in gear case Loose blade nut or gear adjustment incorrect	Refill Re-assemble parts correctly	Page 9 & 16
4. Heavy vibration	Wrong blade fitted Worn clutch Worn clutch drum or damaged drive insulator	Only use Atom Blade (P/N 43782) Take to service dealer Take to service dealer	
5. Motor will not start	Not connected to power Safety switch - earth leakage circuit breaker (Residual current device) not on faulty lead Motor switch or motor not activating Motor damaged	Reconnect Click to "ON". If it continues to cut out, check cables, house power point. Or house safety switch could be faulty. Take to service dealer Take to service dealer	Page 11
6. Motor lacks power or blade stops rotating	Cutting too deep	Raise cutting depth	Page 7
7. Leaking oil at dust cover	Overfilled gearbox	Clean dust cover and casing, cover leaking area with sealant such as silicon or gasket cement and refit.	
8. Hot extension cord	Using light duty extension cord	Use a heavier gauge/heavy duty extension cord	Page 7

COMPLETE WORKSHOP MANUAL

! NOTE

This information is for persons with suitable servicing experience should this unit ever require workshop repair.

! WARNING

Always disconnect the plug before doing any maintenance or repair work, or cleaning the unit or blade.

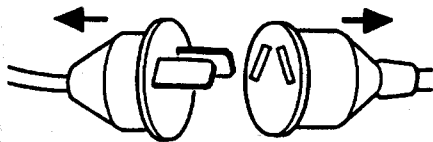

TO SERVICE OR REPAIR UNIT

- A. To Replace Driveshaft.
 - How to remove wheel arm 10
- B. Motor does not switch on. How to adjust switch cable 11
- C. How to repair switch trigger assembly 11
- D. How to remove and replace switch cable, motor clutch and fan 12
- E. How to remove and replace main crown gear and pinion drive shaft 14
- F. Replacing clutch drum – Early model 15
Replacing clutch drum – Late model 15
- G. Final assembly of main housing, gear drive and testing 16-17

A. TO REPLACE BLADE SHAFT

1. After removing blades (Refer Pg 9, Figs 21-24) remove blade drum #43112, felt seal #42112 and spring bevel washers #43115 if fitted. Inspect threaded end of shaft and file off any rough surfaces so shaft is round and smooth.

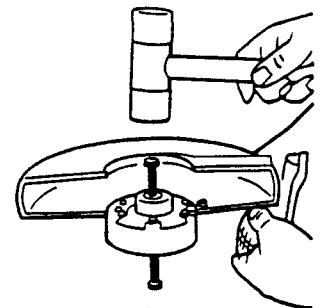

FIG 27

2. Hold unit as shown in Fig. 27 and tap shaft through using a 3/8 bolt or similar so that bolt replaces shaft and maintains alignment and contains washers, spacer and gear inside housing - DO NOT TURN HOUSING OVER.

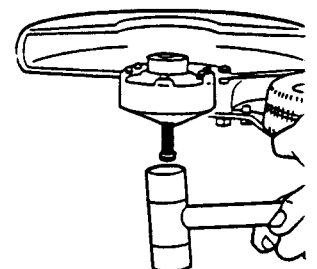

FIG 28

COMPLETE WORKSHOP MANUAL (CONTINUED)

3. Carefully push new blade shaft #43114 up into bearing and tap through carefully so washers, crown gear and spacer remain in position and the 3/8 bolt is pushed out (Fig. 28).

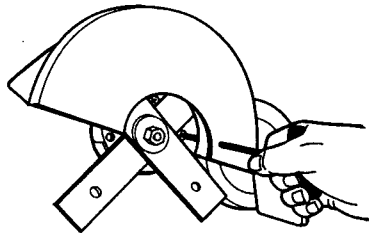

FIG 29A

4. When blade shaft comes through, turn assembly over. Tap blade shaft so head of shaft is against bearing.

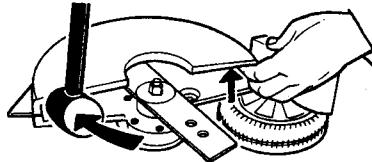

FIG 29B

TO REMOVE WHEEL ARM

1. Remove one screw and washer through hole in blade cover (Fig. 29A). Pull wheel arm assembly out of edger body.

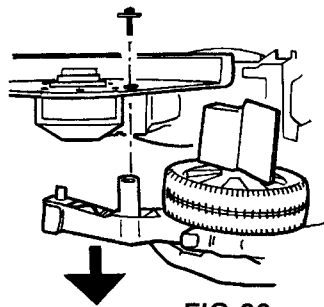

FIG 30

2. Remove blade cover lid by lifting and tapping in a clockwise direction (Fig. 29).

B. ADJUSTING INNER AND OUTER MOTOR SWITCH CABLES

If the motor does not switch on re-adjust cable as follows.

Loosen 2 screws. Pull black outer cable outwards, retighten screws in this position. Motor should now switch on. When you switch on you can hear a "click" in the motor casing (Fig.31).

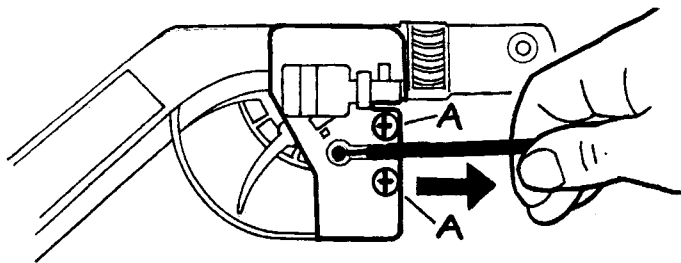

FIG 31

C. TO REPAIR SWITCH TRIGGER ASSEMBLY

1. Remove 2 screws (A) as shown in Fig 31 and remove cover and all parts. Re-assemble as follows.

2. Fit switch inter-lock and compression spring (Fig 32).

3. If fitted with switch trigger torsion spring, place torsion spring over post and hold back with thumb (Fig. 33). Fit switch trigger fully over post and release spring so it catches throttle trigger.

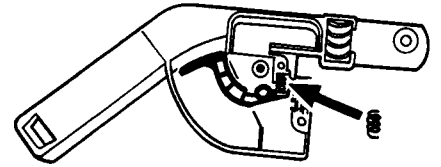

FIG 32

4. If fitted with switch trigger with top hook #43288 and switch trigger compression spring #43198, fit trigger then compression spring (Fig.34).

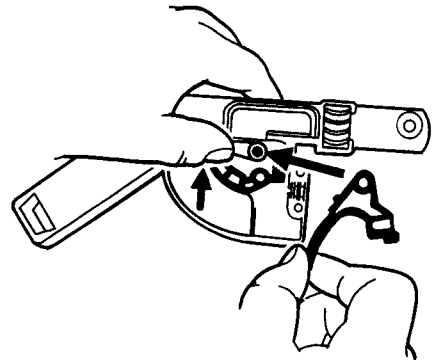

FIG 33

5. Hold trigger in place with finger until switch cover #44069 is fitted (Fig 35). It is then ready for screwing tight (with 2 screws (A) as shown in Fig 31). Ensure switch cover rear lug (arrowed Fig. 35) engages underside of handle wall.

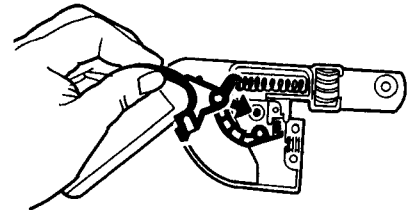

FIG 34

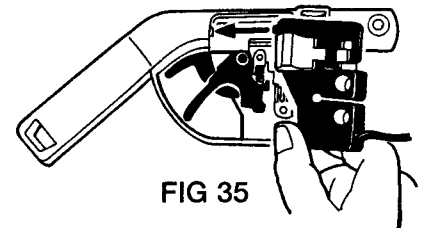

FIG 35

D. HOW TO REMOVE AND REPLACE SWITCH CABLE, POWER CABLE, MOTOR CLUTCH AND FAN

Stand unit against bench or wall as illustrated. Use a stool for ease of working (Fig. 36).



FIG 36

COMPLETE WORKSHOP MANUAL (CONTINUED)

Use Torx No.25 Screwdriver. Do not use straight blade screwdriver as it will strip groove in screw head. remove rear cover 4 screws.

Remove inner casing 4 screws.

Disconnect throttle switch control lever by lifting out with throttle cable. Remove 2 wires from motor by carefully pulling off motor tags. Remove wiring loom assembly.

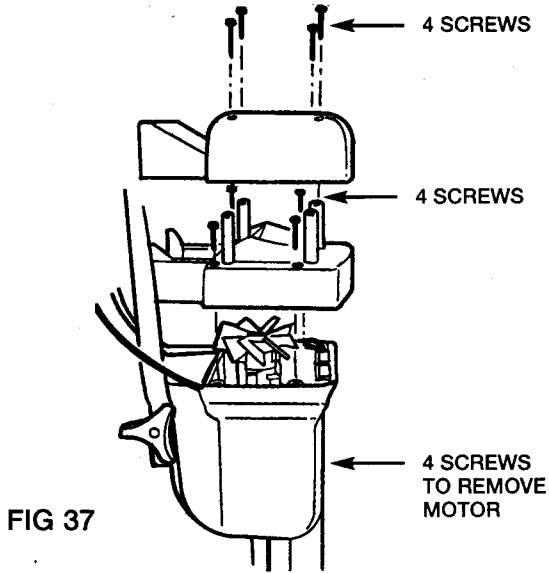

FIG 37

TO REPLACE SWITCH CABLE

1. Loosen 2 switch trigger cover screws (A). Pull outer cable forward and lift inner cable and lug out of slot in cover (Figs 38 & 39).

2. To replace switch cable, reverse above procedure. Outer cable must be pushed fully in before screwing down cover screws (Fig. 40). If motor does not switch on see (B) Fig. 31, P. 11.

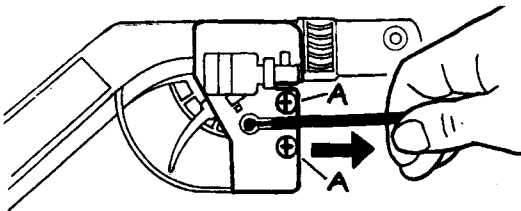

FIG 38

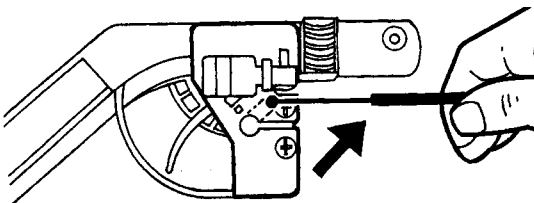

FIG 39

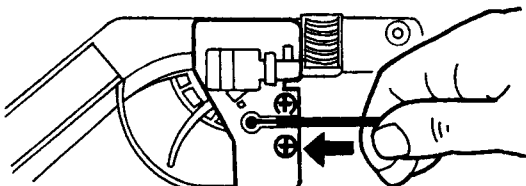

FIG 40

3. At motor end, lift cable out of casing reverse procedure to install (See Fig. 40A).

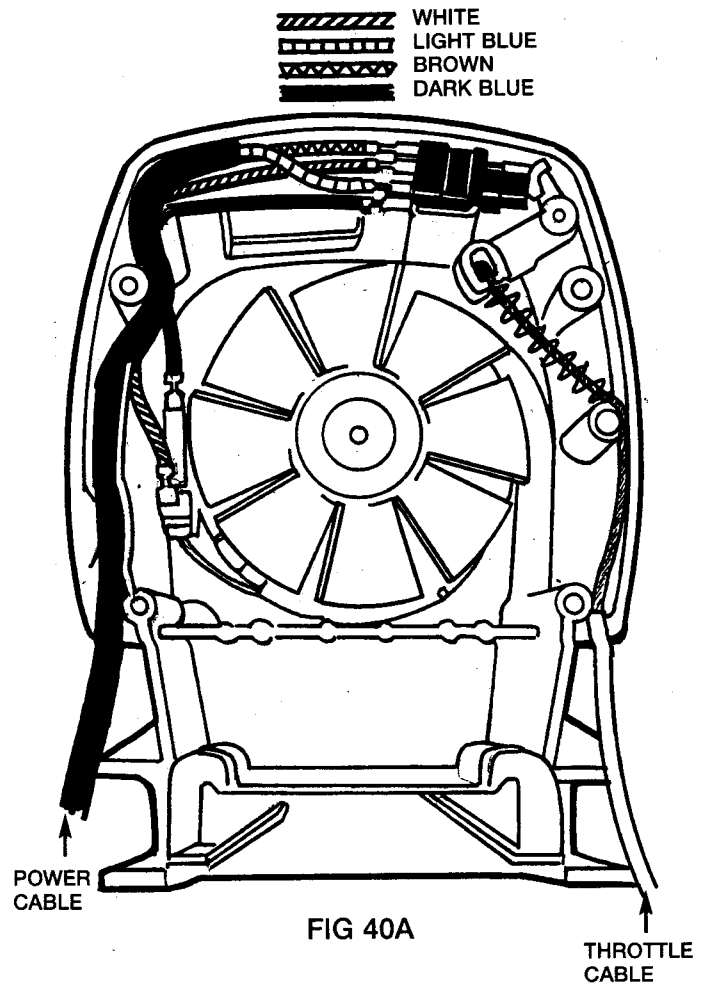

FIG 40A

TO REPLACE POWER WIRE, CABLE, SWITCH AND LEADS

1. Remove 2 wires blue/white from motor by carefully pulling up motor tags "A" (Fig. 40A). Remove wiring loom assembly.

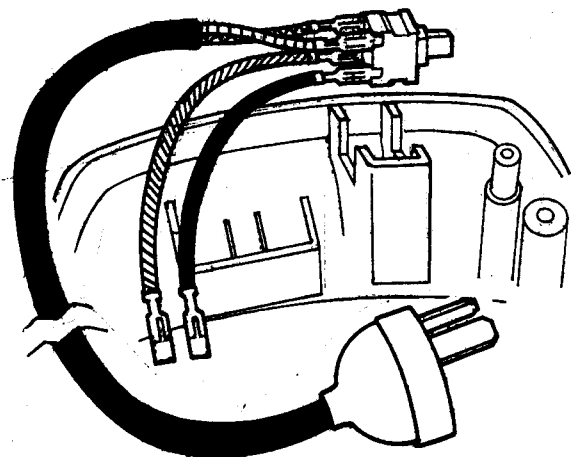

FIG 40B

TO REMOVE AND RE-INSTALL MOTOR

1. Remove 4 screws holding motor and lift motor assembly out (Fig. 43 & 44).

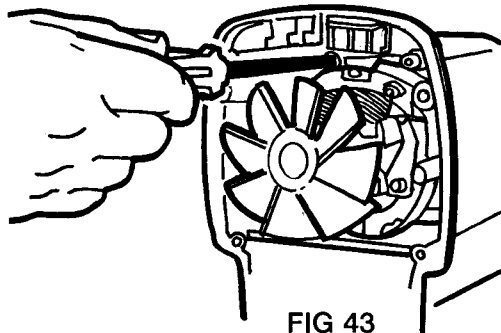

FIG 43

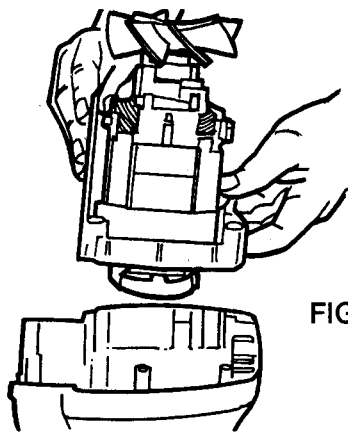

FIG 44

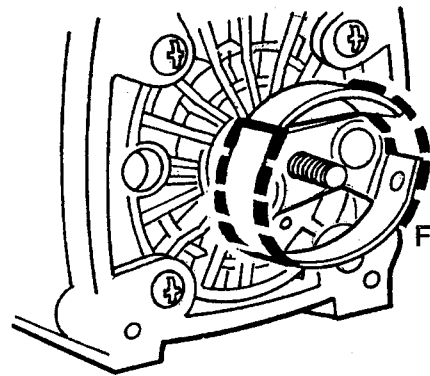

FIG 45

! WARNING Remove clutch to test motor. Only run motor and clutch together only if installed correctly in edger body.

FAN

If blades broken, cracked or pieces missing, replace by levering off carefully and tapping new fan on.

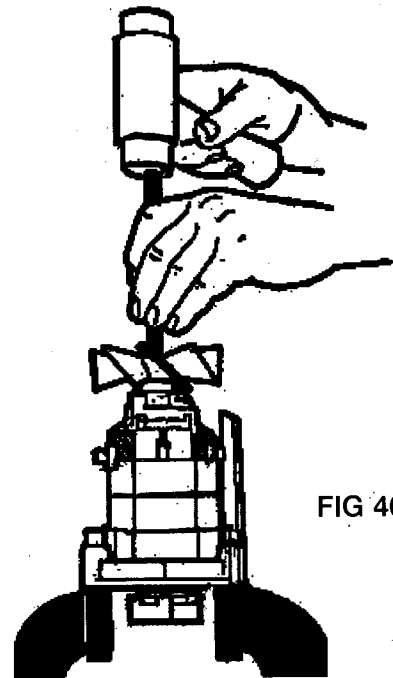

FIG 46

! NOTE

If motor cannot be pulled out after all screws are removed it is possible the double insulation protection polymer material has melted causing shoes and clutch drum to fuse together. To remove, proceed to "Remove Gear and Main Assembly Shaft" Page 14. Removing shaft from casing also allows motor to be extracted.

CLUTCH

The clutch is a 2 shoe springless type. It is self adjusting for wear. If it is badly scored, worn or burnt due to operator running motor without blade turning, remove by knocking to spin off. Anti-clockwise to remove. Clockwise to replace. It is self tightening. Before installing motor and clutch to unit place very thin packaging tape (eg. cello tape) over shoes as illustrated so it can be installed easily into clutch drum (Fig. 45).

! NOTE

Later clutch assembly hub also acts as a electrical insulator and a safety device if operator overloads motor, continuous jamming of blade and overheating of motor. Hub will melt and protect motor like a fuse.

MOTOR

If motor was working previously, re-install carefully by placing 4 screws in 4 corners of motor mount and carefully lower into body. Tighten screws criss-cross until tight. 25 inch/lbs (2.5NM). Make sure clutch shoes fit inside clutch drum.

! NOTE

If motor has been burnt out, eg. commutator or wiring, it can be replaced with a new motor.

! NOTE

Check commutator for wear, burnt, rough or missing pieces and if found in this condition, motor should be replaced. The brushes are very long and will last a long time if commutator in good condition.

E. HOW TO REMOVE AND REPLACE MAIN CROWN GEAR AND PINION DRIVE SHAFT

REMOVE WHEEL ARM

1. Remove blade cover lid by lifting and tapping in a clockwise direction (Fig 47).

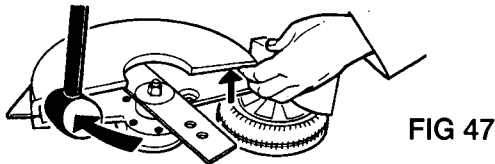

2. Remove one screw and washer through hole in blade cover (Fig 48). Pull wheel arm assembly out of edger body.

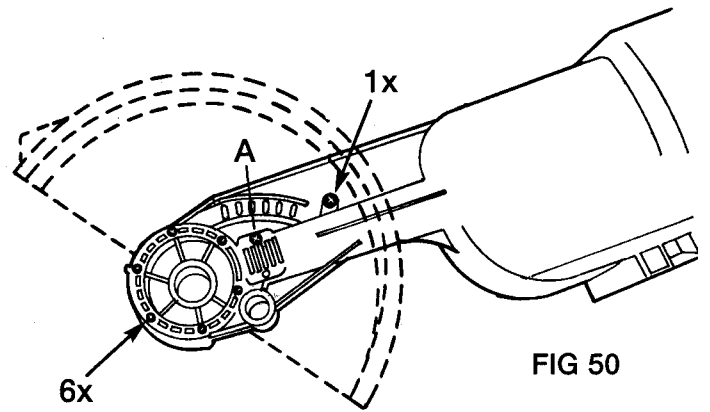
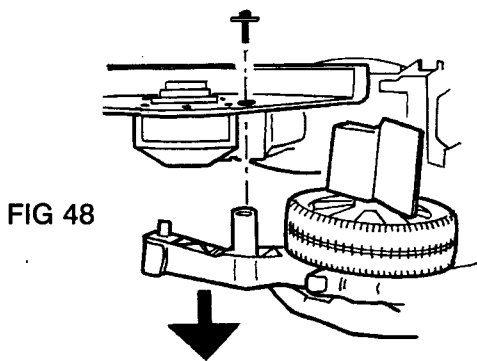

5. Remove bearing holding screw (A) (Fig.50).

6. Using a screwdriver, lever pinion back, turn screwdriver on edge to force back further (Fig. 51 & 52).

7. With a copper or brass punch (a 7/16" brass or copper shaft about 10" long), hold housing and tap pinion shaft out (Fig. 53).

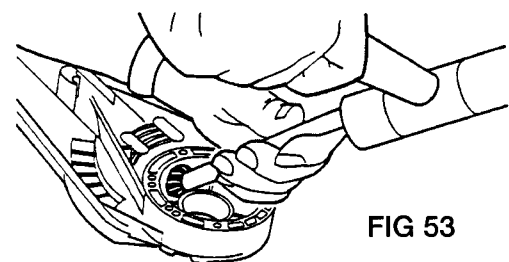
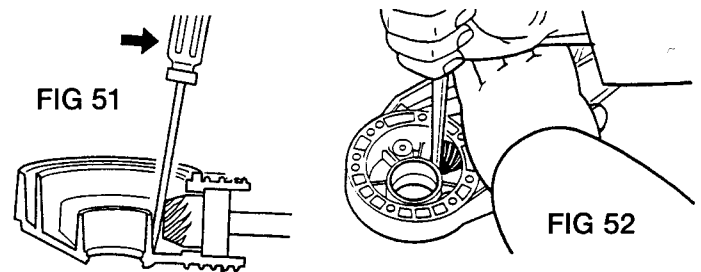

! NOTE

Following only applies to early models with polymer clutch drum if it is to be replaced. Refer also to "Removing and Replacing Clutch Drum" Late model (P.15).

REPLACING CLUTCH DRUM AND REMOVING SHAFT

1. Remove blade cover lid and wheel arm as shown (Fig. 47).

2. Remove 7x screws holding main blade cover/bearing housing. (Fig. 50).

3. Turn edger over to remove dust cover (Refer Pg 9, Fig 21).

4. With a soft punch, tap hex end of blade shaft as in Fig. 49 until cover and gear assembly pops out of body housing.

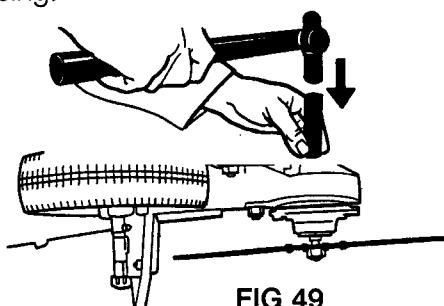

! NOTE

DO NOT USE A STEEL DRIFT as a punch as you will damage the pinion teeth.

COMPLETE WORKSHOP MANUAL (CONTINUED)

REMOVING AND REPLACING CLUTCH DRUM - EARLY MODELS

1. Remove main drive pinion shaft as above.
2. Remove 3/16 x 1" roll pin (P/N 43184) by punching out (Fig 47). Slide off clutch drum, check shaft and straighten if necessary. Slide on new hub/drum, carefully line up hole and re-fit with new pin.

! NOTE Clutch drum hub on early models is an electrical insulator. It is also a safety device, if operator overloads or overheats motor by continuous jamming of the blade it will melt and protect motor. How to remove (Fig.54).

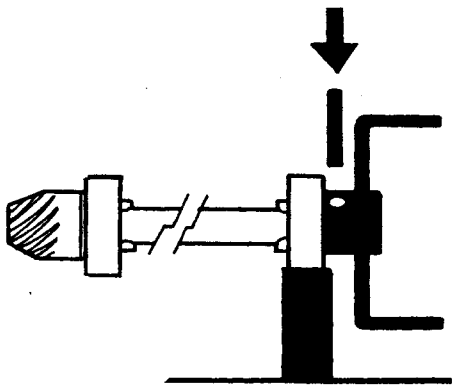

FIG 54

TO REMOVE PINION

1. Hold shaft in vice between two pieces of aluminum so as not to damage shaft.
2. To remove pinion, grip shaft just behind bearing in jaws of vice (Fig. 55) and unscrew pinion counter (anti) clockwise (normal thread) with vice grips. If tight, heat to break loctite seal.

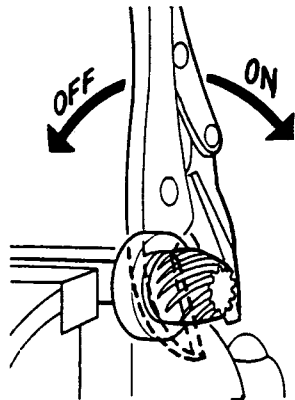

FIG 55

3. Fit new pinion with fresh loctite on thread, making sure it is tight up to spacer washer #43229, (Fig. 56) and washer does not move.

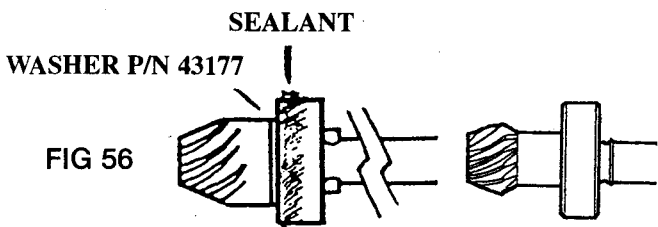

FIG 56

! NOTE Later models do not have washer (P/N 43177) fitted.

REMOVING AND REPLACING CLUTCH DRUM - LATE MODELS

1. There is no requirement to remove main drive pinion shaft.
2. After removal of motor use an extension drive or an impact wrench fitted with a 9/16" socket (Fig 57).

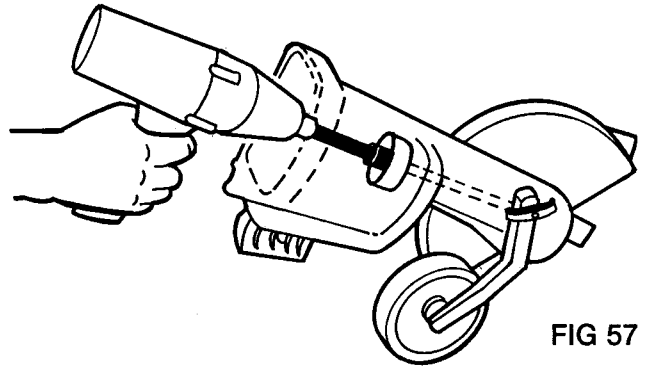

FIG 57

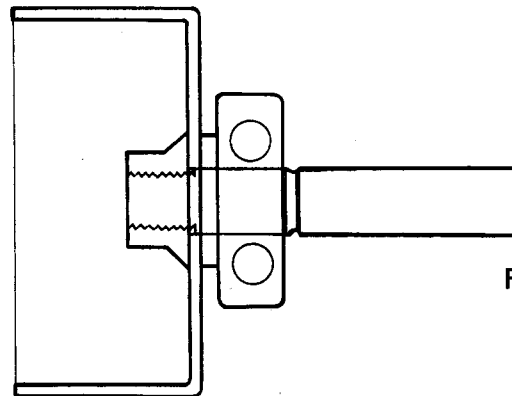

FIG 58

! NOTE Remove clutch drum and replace. Only hand tighten flange clutch nut or very lightly with impact wrench. Overtightening with impact wrench can cause bearing to move forward excessively.

! NOTE The clutch hub on later models is the electrical insulator. It is also a safety device, if operator overloads or overheats motor by continuous jamming of the blade it will melt and protect motor.

! NOTE To replace complete shaft follow instructions, Page 14.

COMPLETE WORKSHOP MANUAL (CONTINUED)

F. ASSEMBLING OF MAIN HOUSING, GEAR DRIVE AND TESTING

1. Clean and dry pinion bearing. Place oil resistant gasket sealant (e.g. Fullerprene 303) around bearing (Fig. 56).
2. Hold pinion shaft assembly vertically and slide into casing A and B (Fig. 59).
3. With a soft punch drive shaft to bottom of casing (Fig. 59).
4. Fit bearing screw (Fig. 50).
5. Lever pinion back to holding/locating screw (Fig. 60).

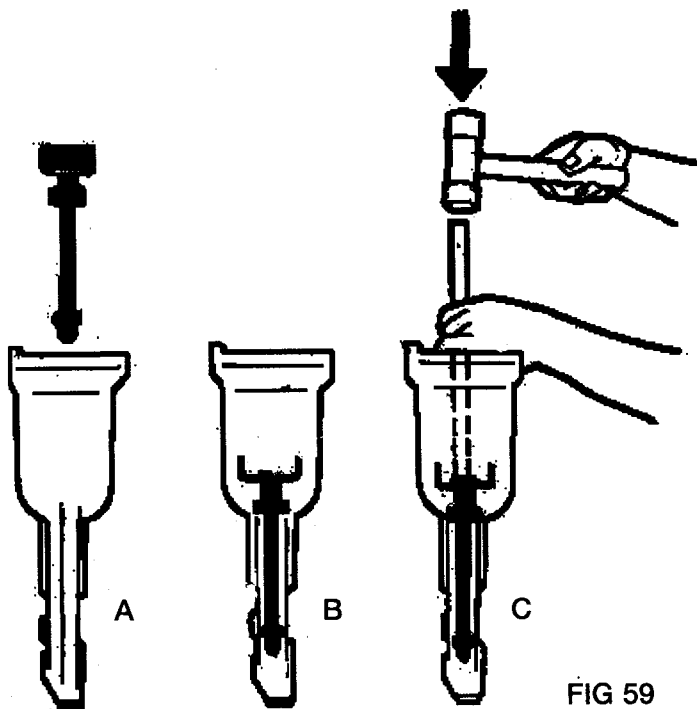

FIG 59

! NOTE Bearing must be forward to allow bearing locating screw to be fitted, then pinion and bearing forced back onto screw. If this is not done, pinion or crown gear could be tight. Correct distance is 6mm (.236") Fig. 60.

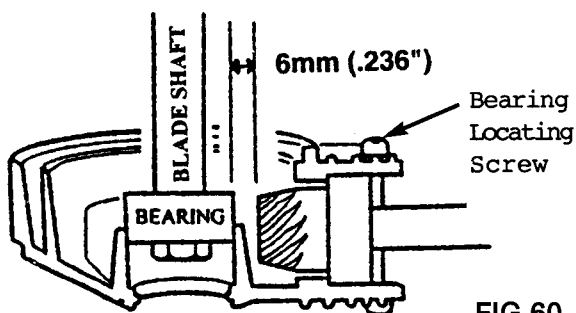

FIG 60

6. Replace crown gear if teeth are worn. See sequence of assembly (Fig. 61 - early models, Fig. 62 - late models).

7. Check and renew 'O' ring #40906 if necessary (no 'O' ring fitted to late models). Fit assembly into housing. If bearing is loose in housing, smear loctite around bearing before assembling. Carefully drive down (making sure gears are meshing) by gently tapping around bearing area (Fig. 63) and turning clutch drum. Refit 6 screws around shaft.

8. Fill or top up with gear lubricant. See Page 9 "LUBRICATION OF GEARS".

9. Fit blade (see page 9) and bearing cap and check rotation that gears are not binding. It should turn smoothly from clutch end. Backlash at end of blade about 2-4mm. Refit blade cover lid, engine, handles and test.

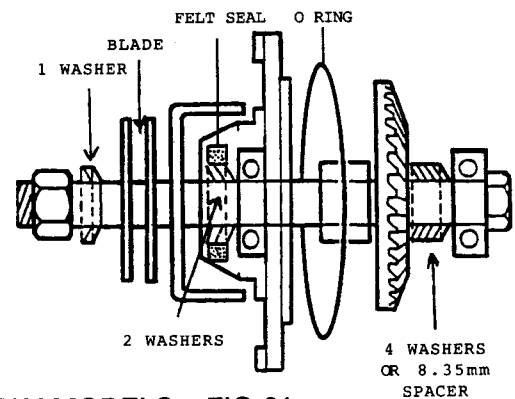

EARLY MODELS - FIG 61

LATE MODELS
FIG 62

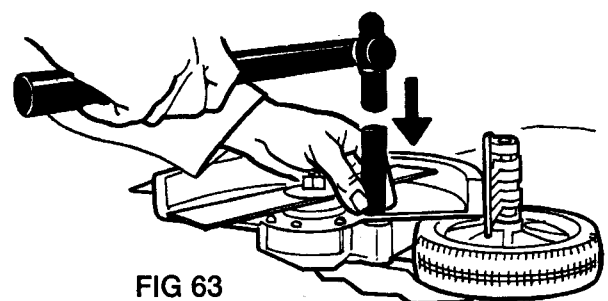
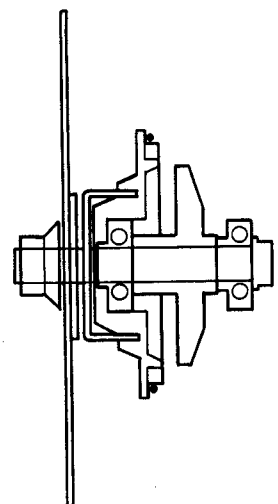

FIG 63

COMPLETE WORKSHOP MANUAL (CONTINUED)

TO COMPLETE ASSEMBLY

Replace motor power cable and switch.

Replace switch lever and cable.

Replace inner casing.

Replace outer casing.

Replace handles etc.

TESTING OF UNIT

Motor and On/Off Switch

After fully assembling and connecting to a power source preferably fitted with an earth leakage circuit breaker, switch unit on and off several times. If switch does not switch on or off, check throttle control to make sure it is free and not jamming and adjusted correctly (see page 11 - Fig. 31). If not working, disconnect power, re-check all wiring, including cables, earth leakage circuit breaks etc.

Testing Clutch

When edging, jam blade in earth and motor will still run at low speed with a burring noise. Only do this for a few seconds.

14/07/2021

ATOM MODEL: 301 ELECTRIC EDGER (Yellow body)

PART NO: 20301

Key	Part No	Substitute Part No	NLA	Description	Key	Part No	Substitute Part No	NLA	Description	Key	Part No	Substitute Part No	NLA	Description
1	40650			SCREW M5x36 TORX	31	43200			SPRING THROTTLE TRIGGER	61	44067	63812A		ASSY R HDL ELEC 310-710
2	40652			NUT NYLOC M5	32	43752			BODY MAIN ELEC	62	44073	63812A		ASSY R HDL ELEC 310-710
3	40906	65164		O-RING ID 63x2.0	33	43754			COVER BLADE AND BEARING	63	44074	63049		BOLT HEX 6.5 x 1/4 BSW
4	42112		X	(NLA) SEAL FELT	34	43756			COVER BLADE LID	64	44075	63488A		ASSY HANDLE KNOB+NUT
5	43091			BLADE SET ELEC yellow	35	43758			CASING MIDDLE ELECTRIC	65	44078			LARGE WHEEL SEAL
6	43108			BEARING 6301-2RS 37x12x12	36	43760			COVER END COWL (ELEC)	66	44079	63472BP		HANDLE LH DOMESTIC
7	43112			DRUM BLADE	37	43762			MOUNT MOTOR (ELEC)	67	43722		X	THROTTLE TRIGGER
8	43114			SHAFT BLADE DRIVE	38	43763	63436WPK		ASSY WL+A301/410/415/550	68	63474			BEARING 32x10x12
9	43115			WASHER BLADE BEVEL	39	43764			SWITCH LEVER (EARLY MODEL)	69	43764			SWITCH LEVER EARLY MODEL
10	43116			PRO DRUM WASH 45x12.2x2	40	43765	64967BP		EDGER DOM WHEEL	70	43761		X	(NLA)SWITCH LEVER
11	43125			SPACER 15.5mm	41	43767			PIN HEIGHT ADJ	71	43227			GREASE & DISPENSER
12	43128	64378		LABEL WARN BLADE COVER	42	43769			HANDLE HEIGHT ADJ	73	43245			GEAR CROWN EDGER/BUSH
13	43133	63466		LABEL HANDLE SAFETY	43	43770	62936WN		DUST CAP EDGER	74	43176			GEAR PINION 25.5mm
14	43173			NUT M12 x 1.75 RH	44	43772			FAN ELEC	75	43773	63356	X	SHAFT ELEC
15	43178	43176		GEAR PINION 25.5mm	45	43776	63356	X	ASSY BODY 301/MOTOR	76	43289			DRUM CLUTCH 67x32x12
16	43719			SPRING DEFLECTOR DEBRIS	46	43779		X	(NLA)BRAKE BLADE	77	43163			NUT FLANGE 3/8 UNC
17	43184	63275		PIN ROLL 5x30 DR/TL	47	43781		X	CLUTCH	78	43792		X	(NLA)SWITCH 240V(ELEC)
18	43187	43289		DRUM CLUTCH 67x32x12	48	43784			CABLE THR ASSY(ELEC)301	79	43865			BEARING 37x12x12 + 2.5mm
19	43198			SPRING TRIGGER COMPRESS	49	43788	63356	X	MAIN SHAFT(ELEC)	80	43736	63812A		ASSY R HDL ELEC 310-710
20	43199			SPRING SMALL	50	43790			SCREW M5.5x22 TORX	82	43740		X	(NLA) WIRE BLUE ELECTRIC
21	43229			WASHER .050 PINION	51	43791	63382		SWITCH ELEC 10AMPS	83	43794			CABLE & PLUG 240V(ELEC)
22	43240	43245		GEAR CROWN EDGER/BUSH	52	43797			CABLE & PLUG ELECTRIC					
23	43288			TRIGGER THROTTLE	53	21775			MANUAL ALL MODELS					
24	43292			INTERLOCK THROTTLE	54	43860			BEARING 32x10x12 + 4mm					
25	43452			SPRING HT ADJ ARM COMPR	55	44006			NUT 1/4 UNC ZP (10.9mmAF)					
26	43715			FLAP GRASS BLACK	56	63436WPK			ASSY WL+A301/410/415/550					
27	43719			SPRING DEFLECTOR DEBRIS	57	44060			HANDLE TUBE					
28	43721	44308		GRASS SHIELD LIMITER PRO	58	44061	44060		HANDLE TUBE LH					
29	43743			WIRE BLUE W/TERMINAL	59	44062	63020WE		HANDLE CROSS BRACE					
30	43745			WIRE WHITE W/TERMINAL	60	44064B	63187BN		CAPTIVE PLATE 1/4 HEX BOLT					

Atom warrants each new Atom Edger Model 205 for ONE YEAR for residential use based on the following terms.

This warranty extends to the original retail purchaser only and commences on the date of the original retail purchase.

Any part of the Atom Edger manufactured or supplied by Atom and found in the reasonable judgement of Atom to be defective in material or workmanship will be repaired or replaced by an authorized Atom service dealer without charge for parts and labor.

The Atom Edger, including any defective part, must be returned to an authorized service dealer within the warranty period. The expense of delivering the Atom Edger to the dealer for warranty work and the expense of returning it back to the owner after repair or replacement will be paid for by the owner. Atom's responsibility in respect to claims is limited to making the required repairs or replacements and no claim of breach of warranty shall be cause for cancellation or rescission of the Contract of Sale of any Atom Edger. Proof of purchase will be required by the dealer to substantiate any warranty claim. All warranty work must be performed by an authorized Atom service dealer or by Atom.

This warranty is limited to NINETY (90) days from the date of original retail purchase for any Atom Edger that is used for commercial purposes and ONE (1) month for rental purposes.

This warranty does not cover any Atom Edger that has been subject to misuse, neglect, negligence or accident, or that has been operated in any way contrary to the operating instructions as specified in the Atom Operator's Manual. This warranty does not apply to any damage to the Atom Edger that is the result of improper maintenance or to any Atom Edger that has been altered or modified so as to adversely affect the product's operation, performance or durability or that has been altered or modified so as to change its intended use. The warranty does not extend to repairs made necessary by normal wear or by the use of parts or accessories which are either incompatible with the Atom Edger or adversely affect its operation, performance or durability.

Atom reserves the right to change or improve the design of any Atom Edger without assuming any obligation to modify any product previously manufactured.

ALL IMPLIED WARRANTIES ARE LIMITED IN DURATION TO THE ONE YEAR WARRANTY PERIOD OR NINETY (90) DAYS FOR PRODUCTS USED FOR ANY COMMERCIAL PURPOSE AND ONE (1) MONTH FOR RENTAL PURPOSES. ACCORDINGLY, ANY SUCH IMPLIED WARRANTIES, INCLUDING MERCHANTABILITY, FITNESS FOR A PARTICULAR PURPOSE, OR OTHERWISE, ARE DISCLAIMED IN THEIR ENTIRETY AFTER THE EXPIRATION OF THE APPROPRIATE TWELVE (12) MONTHS OR

THIRTY (30) DAY WARRANTY PERIOD. ATOM'S OBLIGATION UNDER THIS WARRANTY IS STRICTLY AND EXCLUSIVELY LIMITED TO THE REPAIR OR REPLACEMENT OF DEFECTIVE PARTS AND ATOM DOES NOT ASSUME OR AUTHORIZE ANYONE TO ASSUME FOR THEM ANY OTHER OBLIGATION. SOME STATES DO NOT ALLOW LIMITATIONS ON HOW LONG AN IMPLIED WARRANTY LASTS, SO THE ABOVE LIMITATION MAY NOT APPLY TO YOU.

ATOM ASSUMES NO RESPONSIBILITY FOR INCIDENTAL, CONSEQUENTIAL OR OTHER DAMAGES INCLUDING, BUT NOT LIMITED TO, EXPENSE OF RETURNING THE ATOM PRODUCT TO AN AUTHORIZED SERVICE DEALER AND EXPENSE OF DELIVERING IT BACK TO THE OWNER, MECHANIC'S TRAVEL TIME, TELEPHONE OR TELEGRAM CHARGES, RENTAL OF A LIKE PRODUCT, DURING THE TIME WARRANTY SERVICE IS BEING PERFORMED, TRAVEL, LOSS OR DAMAGE TO PERSONAL PROPERTY, LOSS OF REVENUE, LOSS OF USE OF THE PRODUCT, LOSS OR TIME, OR INCONVENIENCE. SOME STATES DO NOT ALLOW THE EXCLUSION OR LIMITATION OF INCIDENTAL OR CONSEQUENTIAL DAMAGES SO THE ABOVE LIMITATION OR EXCLUSION MAY NOT APPLY TO YOU.

This warranty gives you specific legal rights, and you may also have other rights which vary from state to state.

This warranty applies to Atom Edger Model 205 manufactured by Atom.

IMPORTANT: PLEASE FILL OUT THE INFORMATION BELOW ON PURCHASE

DATE OF PURCHASE: _____	Keep this manual as proof of purchase. This is your Lawn Edger machine model number. Should you ever require any parts, please quote these numbers. Lawn Edger No: _____ Record number printed on label of body Model No: 301 Catalogue No: 20301
PURCHASED BY: _____	
Address: _____ _____	
State: _____ Post/Zip Code: _____	
SOLD BY: _____	
Address: _____ _____	
State: _____ Post/Zip Code: _____	

Atom Edgers are manufactured in Australia and exported around the world.

Aust. Patent No. 678575.

US Patent No's 5,826,667 & 6,116,350.

Other Australian and US Patents pending. Patent Pending in Europe, Japan and elsewhere.

Design registrations granted in Australia, USA, Japan and Great Britain.

Patents pending on Cross-Blade system.

Operator Manual. Part No. 43986. Printed in Australia.

Copyright © 2006 Atom Industries. All rights reserved.

///ATOM® Industries

Atom Industries

9 Fred Street, Lilyfield NSW 2040 Australia

PO Box 513 Rozelle NSW 2039 Australia.

Phone: (02) 9810 0194 • International: (+61) 2 9810 0194

Fax: (02) 9810 6691 • International: (+61) 2 9810 6691

Email: info@atomindustries.com.au

Atom Industries is a division of Solo Industries Pty Ltd (ACN 000 583 924).

Patents and registrations granted and pending.

website: www.atomindustries.com.au

Atom Industries (NZ) Limited

PO Box 23500 Papatotoe, Auckland New Zealand.

Phone: (02) 9810 0194 • International: (+61) 2 9810 0194

Fax : (02) 9810 6691 • International: (+61) 2 9810 6691

Email: info@atomindustries.co.nz

Patents and registrations granted and pending.

website: www.atomindustries.co.nz